

Overdrive Clutch Hub Bushing

92004-LOS Housing I.D. Size .9410
5 Bushings Late Design

92004-L Housing I.D. Size .9370
5 Bushings Late Design

92004-SP Housing I.D. Size .9590
5 Bushings Early Design

Note:
92004-LOS is for the later design
(1996 & up) 41TE, 42LE
Housing Dia. .9410

92004-L is for the later design
(1996 & up) 41TE, 42LE
Housing Dia. .9370

92004-SP is for the early design
(1995 & earlier) 41TE
Housing Dia. .9590

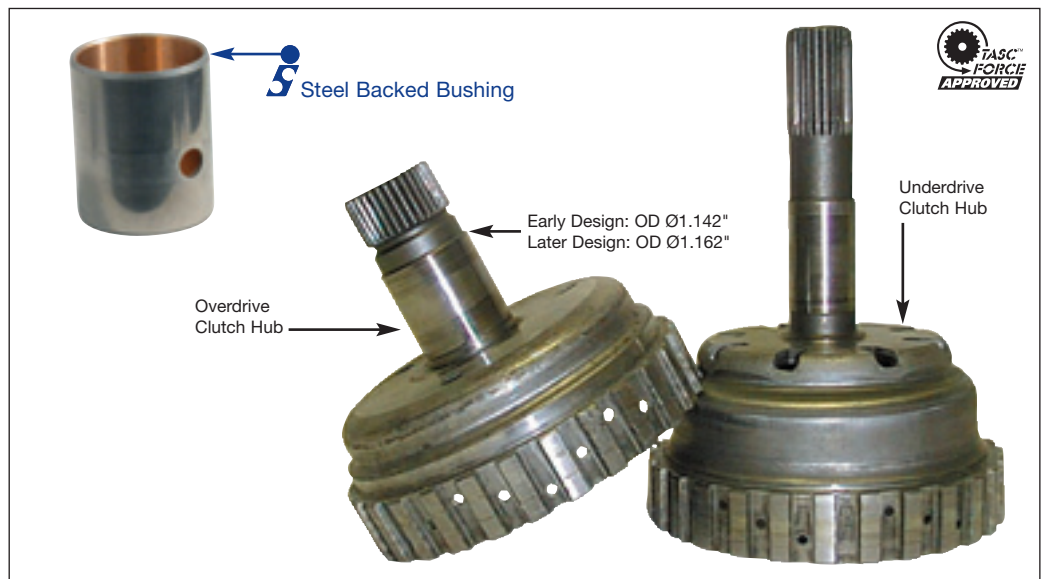

Installation Instructions

1. Remove the two OEM steel-backed bushings from the inside diameter of the overdrive clutch hub shaft.
2. Verify correct part number application. Plug gauge not supplied by Sonnax (see supplied drawing for making a plug gauge).
3. Press the replacement bushing into the overdrive shaft, making sure that the cross hole lines up with the cross hole in the overdrive shaft.

92004-L, 92004-LOS, 92004-SP, OD CLUTCH HUB

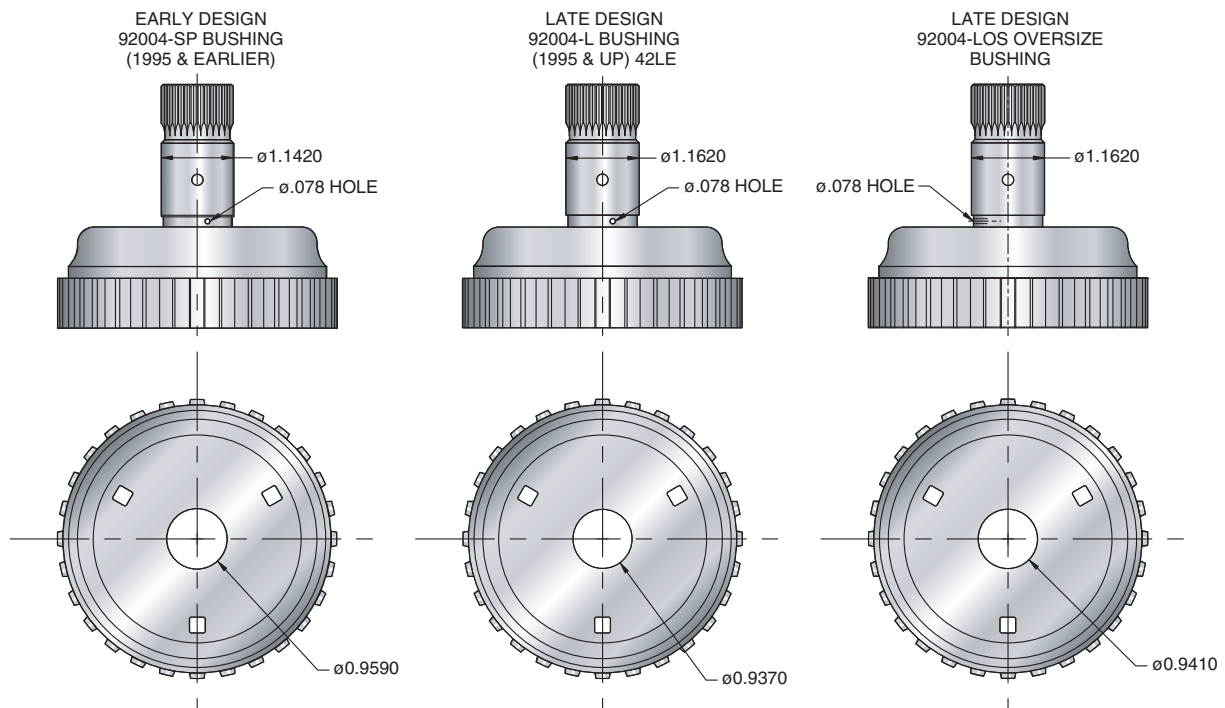

41TE 42LE

PART NUMBERS 92004-L, -LOS, -SP

Overdrive Clutch
Hub Bushing

PLUG GAUGE DRAWING FOR CHRYSLER (41TE),(42LE)
OVERDRIVE CLUTCH HUB BUSHING

